

8.1.4 BF Series

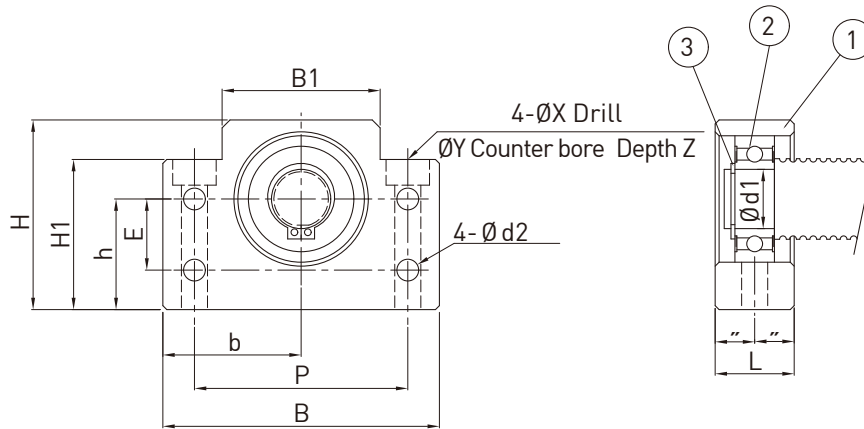

Part No.	Part name	Qty
1	Housing	1
2	Bearing	1
3	Snap ring	1



Specification	Main dimensions (mm)																Weight (kg)
	d1	L	B	H	b (Note 1)	h (Note 1)	B1	H1	E	P	d2	X	Y	Z	Bearing	Snap ring	
BF10	8	20	60	39	30	22	34	32.5	15	46	5.5	6.6	10.8	5	608ZZ	S08	0.3
BF12	10	20	60	43	30	25	34	32.5	18	46	5.5	6.6	10.8	1.5	6000ZZ	S10	0.35
BF15	15	20	70	48	35	28	40	38	18	54	5.5	6.6	11	6.5	6002ZZ	S15	0.4
BF17	17	23	86	64	43	39	50	55	28	68	6.6	9	14	8.5	6203ZZ	S17	0.75
BF20	20	26	88	60	44	34	52	50	22	70	6.6	9	14	8.5	6004ZZ	S20	0.77
BF25	25	30	106	80	53	48	64	70	33	85	9	11	17	11	6205ZZ	S25	1.45
BF30	30	32	128	89	64	51	76	78	33	102	11	14	20	13	6206ZZ	S30	1.95
BF35	35	32	140	96	70	52	88	79	35	114	11	14	20	13	6207ZZ	S35	2.25
BF40	40	37	160	110	80	60	100	90	37	130	14	18	26	17.5	6208ZZ	S40	3.3

Note: 1. Tolerance of Height (h) and tolerance of Width (b) refer to the precision of standard bearing.

2. Specification are subject to change without notice.